

# EDM Tool Marker Vise (STAINLESS) VERTEX®

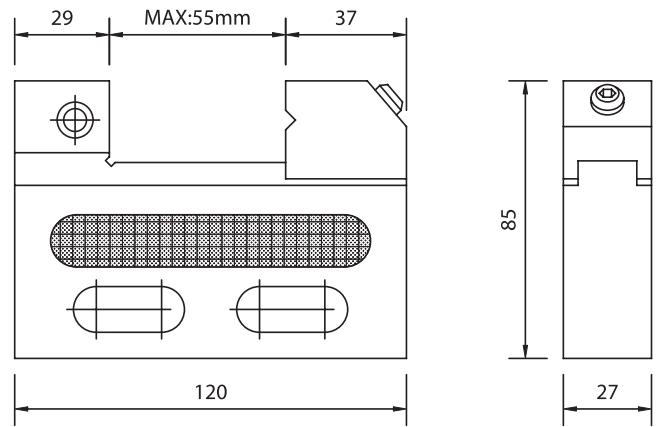

Material: SUS 440  
 Hardness: HRC 58°~60°  
 Squareness: Within 0.005 mm

This vise is for wire cutter use. Each of the parts was manufactured by stainless steel and with the appliance of high erosion resisting.

<b>PARALLELISM</b>	±0.002 mm / 100 mm	
<b>SQUARENESS</b>	±0.002 mm / 100 mm	
<b>ORDER NO.</b>	<b>WEIGHT (kgs)</b>	<b>CODE NO.</b>
VSTV-50W	1.4	2008-040

<b>MAX.OPENING</b>	55 mm
<b>THICKNESS</b>	27 mm
<b>JAW DEEP</b>	25 mm
<b>N.W</b>	1.01 kgs
<b>MATERIAL</b>	SUS 440
<b>HARDNESS</b>	HRC 54°±2°

# EDM Tool Maker Vise (STAINLESS)

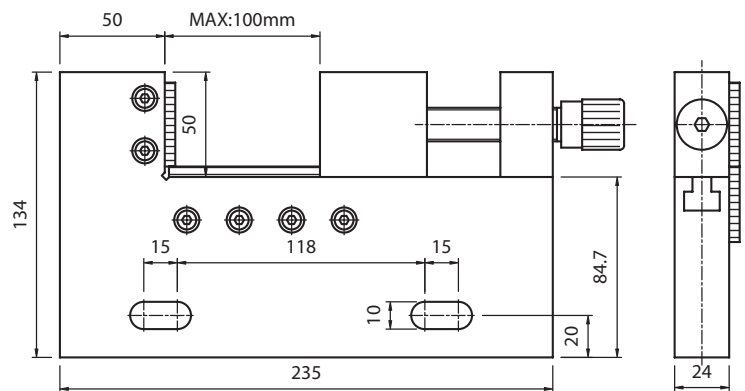
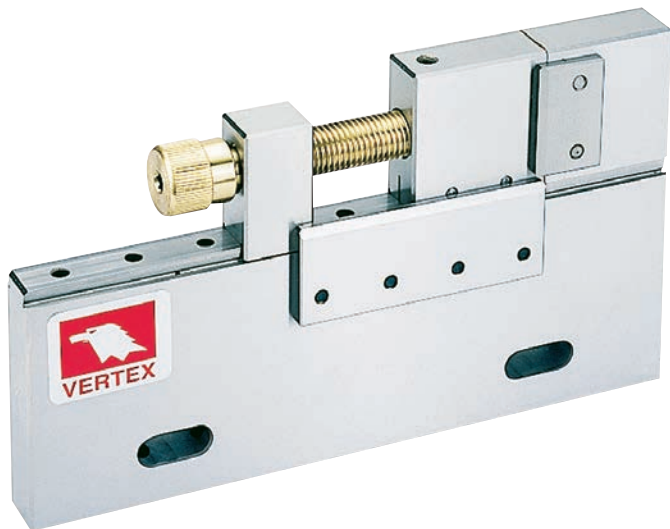

● Do not over lock.

<b>PARALLELISM</b>	±0.002 mm / 100 mm	
<b>SQUARENESS</b>	±0.002 mm / 100 mm	
<b>ORDER NO.</b>	<b>WEIGHT (kgs)</b>	<b>CODE NO.</b>
VSTV-100W	4.88	2008-050

<b>MAX.OPENING</b>	100 mm
<b>THICKNESS</b>	24 mm
<b>JAW DEEP</b>	50 mm
<b>N.W</b>	4.88 kgs
<b>MATERIAL</b>	SUS420
<b>HARDNESS</b>	HRC 54°±2°